



*An Online CPD Course
brought to you by
CEDengineering.ca*

HVAC – Natural Ventilation Principles and Practices

Course No: M04-038
Credit: 4 PDH

A. Bhatia



Continuing Education and Development, Inc.

P: (877) 322-5800
info@cedengineering.ca

HVAC – NATURAL VENTILATION PRINCIPLES AND PRACTICES

Natural ventilation, as the name implies, is a system using natural forces to supply fresh air for comfort and heat dissipation. As an alternative to mechanical (fan-forced) ventilation, this approach relies on the natural forces of wind and buoyancy to deliver fresh air to indoor spaces. Natural ventilation may be divided into two categories:

1. **Controlled natural ventilation** is intentional displacement of air through specified openings such as windows, doors, and ventilators. It is usually controlled to some extent by the occupant.
2. **Uncontrolled ventilation (Infiltration)** is the random flow of air through unintentional infiltration through cracks, gaps or crevices in the building structure. It is less desirable and can be controlled only by plugging the gaps.

Natural ventilation has several benefits: low running cost, zero energy consumption, low maintenance and probably lower initial cost. It is regarded as healthier, and the way it connects with the outside is seen as a psychological benefit. The effectiveness of natural ventilation is determined by the prevailing outdoor conditions: microclimate (wind speed, temperature, humidity and surrounding topography) and the building itself (orientation, number of windows or openings, size and location).

The alternative to natural ventilation is mechanical ventilation, which uses one or more electrical fans or blowers to move air in and out. The primary advantage of this approach is the consistency and controllability of the rate of ventilation. Other advantages include the opportunities for air filtration and possible heat recovery. The disadvantages are the capital costs, the running costs, the noise, and continuous maintenance.

We will focus on Natural Ventilation in this course.

The design of natural ventilation system necessitates knowledge of the mechanism of air flow through buildings and also of factors which have a bearing on air flow patterns indoors. In this course we will define and discuss three essential aspects of natural ventilation:

1. **Natural Driving Forces.** The first aspect is the natural forces utilized to drive the ventilation. The driving forces can be wind, buoyancy or a combination of both.
2. **Natural Ventilation Principles.** The second aspect is the ventilation principle used to exploit the natural driving forces to ventilate a space. This can be done by single-sided ventilation, cross ventilation, or stack ventilation.
3. **Architectural Elements.** The third aspect is the characteristic architectural elements used to enhance natural ventilation. The most important characteristic elements are wind towers, wind scoops, chimneys, double façades, atria, and embedded ducts.

SECTION - 1: NATURAL DRIVING FORCES

Natural ventilation is provided from two sources: thermal buoyancy and wind.

1. **Wind** - The air moves from higher (positive) pressure regions to the lower (negative) pressures regions. This phenomenon is based on Bernoulli's principle, which uses pressure differences to move air. The pressures generated by natural wind are typically - 0.004 to 0.14 inches of water column (in-wc).
2. **Buoyancy** - The warm air is less dense than cool air so it rises and creates a difference in pressure which in turn induces air movement. This phenomenon is called "the thermal buoyancy" and is sometimes referred to as "the stack effect". The pressures generated by buoyancy are quite low ranging from - 0.001 to 0.01 inches of water column (in-wc).

The magnitude and pattern of natural air movement through a building depends on the strength and direction of these natural driving forces and the resistance of the flow path. Stack ventilation, can operate when no wind pressure is available. (The absence of wind can occur at certain times, due to its variability, or in certain sites, due to blocking effect of other buildings or vegetation). It can also operate in deep plan buildings where the distance from openings in the perimeter, and the presence of partitions, make wind-driven cross ventilation impractical.

The design of natural ventilation system often relies on both these driving forces. The dominating natural driving force has consequences for the shape and layout of the building.

WIND EFFECT

Natural ventilation is induced by differences in air pressure across the building. When wind strikes a building, a region of higher pressure is created on windward wall and a negative pressure on the leeward side of the building façade. A pressure gradient is thereby created across the building in the direction of the incident wind. This pressure gradient around a building in turn creates a negative pressure area inside the building that encourages air to move through the building and via its openings. The air moves through from the opening in the positive pressure façade to the opening in the negative pressure one.

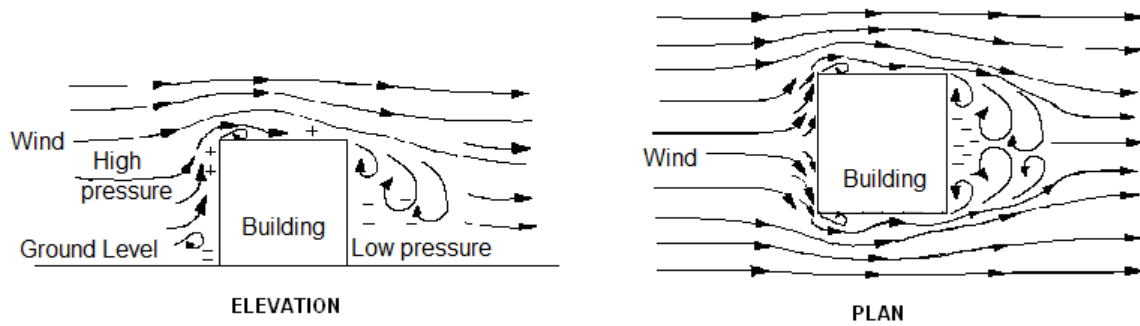

Detail of Airflow around a Building

Wind effect uses Bernoulli's principle of fluid dynamics, which states that at higher speeds the static pressure decreases and at lower speeds the static pressure increases. The air speed on the windward side of the building reduces as it collides with the building, resulting in an increased pressure. Conversely, the air speed on the top and the leeward sides of the building increases, resulting in reduced pressure. A pressure differential is thus created between windward and leeward walls. The effective pressure difference tends to be greatest (about 1.4 times the dynamic pressure at eaves level for typical rectangular buildings) when wall openings are about 15% to 20% of wall area. This means that the average wind speed through wall openings has the potential to be 18% higher than the local wind speed. Without any openings the wind pressure difference is about 1.1 times the dynamic pressure at eaves level. With a 60% wall opening or more, the wind pressure difference between windward and leeward surfaces remains constant around 1.0 times the dynamic pressure at eaves level.

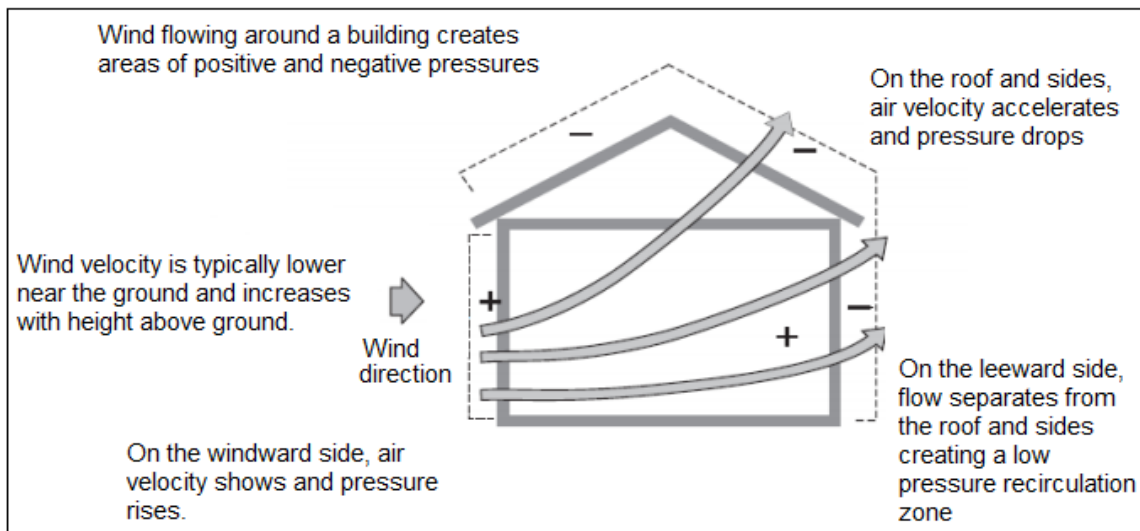

The magnitude of the wind pressure (P) is proportional to the velocity pressure, and is given by:

$$\Delta P = 0.013 \frac{\rho V^2}{2} (c_{p-ww} - c_{p-lw})$$

Where,

- ΔP = Pressure difference from ambient, in-wc
- V = Time-averaged approach wind velocity, mph
- ρ = Air density, lb_m/ft³
- C_{p-ww} = Wind pressure coefficient of windward surface
- C_{p-lw} = Wind pressure coefficient of leeward surface

The value of C_p depends on several factors such as the wind direction, orientation of the building etc. Analytical evaluation of C_p is quite complicated, even though these values have been measured experimentally for simple structures. Typical Design Values (ASHRAE Fundamentals (2009) Chapter 16) are:

$$C_{p-ww} = +0.65$$

$$C_{p-lw} = -0.65$$

Example: Consider a building design that incorporates wind-driven cross-flow at an ambient temperature of 70°F. Determine the wind-driven pressure difference at 0, 5, 10 and 20 mph.

Solution

Density of air at 70°F is 0.075 lb_m/ft³

$$C_{p-ww} = +0.65$$

$$C_{p-lw} = -0.65$$

$$\Delta P = 0.013 (c_{p-ww} - c_{p-lw}) \frac{\rho V^2}{2}$$

$$\Delta P @ 0 \text{ mph} = 0 \text{ in-wc}$$

$$\Delta P @ 5 \text{ mph} = 0.015 \text{ in-wc}$$

$$\Delta P @ 10 \text{ mph} = 0.06 \text{ in-wc}$$

$\Delta P @ 20 \text{ mph} = 0.25 \text{ in-wc}$

Ventilation Calculation from Wind Effect

The rate of wind driven airflow across any opening in the building façade can be calculated by using the empirical power law:

$$Q = C_d \cdot A \cdot V$$

Where,

- Q = Volumetric flow rate through the opening, ft^3/min (cfm)
- A = Free area of inlet openings, ft^2
- V = Air velocity leaving the opening, ft./min (fpm)
- C_d = Discharge coefficient (effectiveness of openings)

The coefficient of discharge “ C_d ” depends upon the direction of the wind relative to the opening and the relative size of entry and exit openings. It ranges from about 0.3 for wind hitting an opening at a 45° angle of incidence to 0.6 for wind hitting directly at a 90° angle. For wind directions outside these limits, the value of C_d may be considered to change linearly with wind direction. The greatest pressure differential around the building occurs when wind strikes it perpendicularly (i.e. largest wind shadow so largest suction effect).

Substituting velocity for pressure drop to the airflow equation, we will see that the airflow is proportional to the square root of the total pressure difference.

$$Q = C_d \cdot A \cdot \left(\frac{2 \Delta P}{\rho} \right)^{1/2}$$

}

Note that pressure drop is related to velocity as discussed in previous paragraph. Simplifying the equation (ignoring wind coefficients):

$$\Delta P = \frac{\rho V^2}{2} \text{ or}$$

$$V = \left(\frac{2 \Delta P}{\rho} \right)^{1/2}$$

Where,

- Q = Volumetric flow rate through the opening in ft^3/min (cfm)
- A = Free area of inlet openings, ft^2

- V = Air velocity leaving the opening, ft/min (fpm)
- C_d = Discharge coefficient (effectiveness of openings)
- Δp = Pressure difference across the opening, in-wc
- ρ = Air density, lb_m/ft³

Example:

With an outdoor wind speed of 250 feet per minute and wind incident normally on the window wall, the quantity of air flow is:

$$Q = C_d \cdot A \cdot V$$

$$Q = 0.6 \times 1\text{ft}^2 \times 250 \text{ ft}^3/\text{min}$$

$$Q = 150 \text{ cfm per sq.ft of opening}$$

Factors Affecting Flow due to Wind

The magnitude of air movement in a building is dependent on the pressure differential between the outlets and inlets, which in turn is dependent on the wind speed, wind direction and building shape. Wind speed increases with height and is lower towards the ground due to frictional drag. The building geometry, relative position and size of openings; building location in relation to surroundings; and the terrain geographical location of the building, create wind flow changes affecting building pressures. The dynamic wind pressure on any specific position on a building's surface (façade) can be calculated using the Bernoulli's equation.

Applications and Limitations of Wind Driven Ventilation:

The relative importance of wind acting directly on an opening may be either an advantage or a disadvantage, depending on the time of year.

- During warm weather, the wind becomes an advantage and techniques are used to take full advantage of the prevailing wind direction.
- During cold and mild weather conditions, the relatively high speed wind can create uncontrolled drafts and discomfort. During cold weather periods, the ventilation should be restricted to minimum rates.

THERMAL BUOYANCY “STACK EFFECT”

The airflow due to thermal buoyancy occurs as a result of the difference between air density which in its turn depends on temperature and humidity between outside and inside the buildings. Cool air is heavier than warm air at the same humidity level and dry air is heavier than humid air at the same temperature level. Due to this warmth, the airflow occurs mainly in the vertical direction through gaps or weak resistance points within the building such as stairwells, elevators, atriums, and shafts. This phenomenon is called “stack effect”.

In winter, when the indoor temperature is higher than the outdoor, the upper parts of the building will have higher pressure while the lower parts will have lower pressure. When openings are provided in these regions, air enters through the lower openings and escapes through the upper. In summer, when the outside air is warmer than the building air, a downward airflow, or reverse stack effect, frequently exists in shafts. Refer to the figure below.

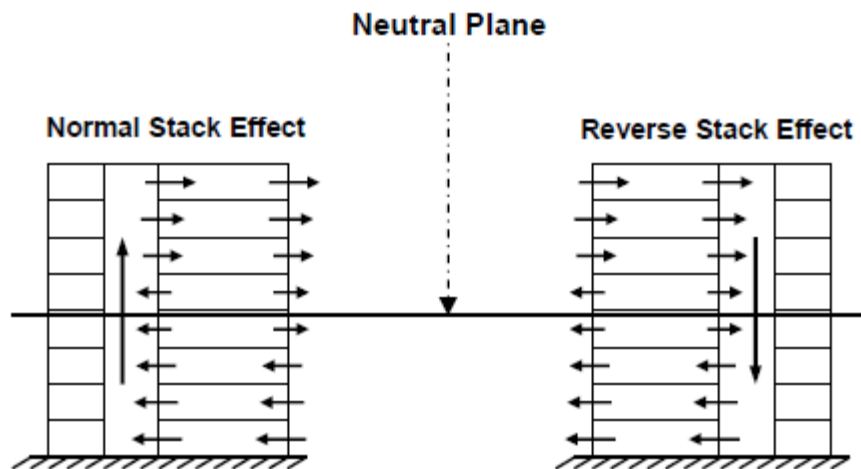

Air Movement Due to Normal and Reverse Stack Effect

When there is no effect of wind force and the thermal buoyancy is acting independently, the level at which both indoor and outdoor pressures are equal, or the pressure difference (ΔP) becomes zero, is called "the neutral pressure level (NPL)". With normal stack effect:

- The air enters the building below the NPL, approximately mid-height, and exits above the NPL.

- Below the NPL there will be an under pressure in the building compared to outside which will make the air flow into the building.
- At NPL, theoretically there is no flow.

The pressure difference due to normal or reverse track effect is expressed as:

$$\Delta P = K_s \times \left(\frac{1}{T_o} - \frac{1}{T_i} \right) \times h$$

Where,

- ΔP = Pressure difference, in-wc
- K_s = Coefficient = 7.64
- T_o = Absolute temperature of outside air, °R
- T_i = Absolute temperature of the air inside the shaft, °R
- h = Distance above neutral plane, ft.

Important: You can observe from the equation that the gradient of pressure created by a stack effect in a building is directly proportional to the vertical height. This means that the stack effect is more pronounced in tall rooms and high-rise buildings.

Example: Consider a 30-foot high atrium with openings to the outside at ground level and roof level. The inside conditions are maintained at 75°F. Determine the hydrostatic pressure differential at ground level and roof level if the outdoor temperature is 40°F.

Solution:

Given,

$$T_o = (40^\circ\text{F} + 459.67) = 499.67^\circ\text{R}$$

$$T_i = (75^\circ\text{F} + 459.67) = 534.67^\circ\text{R}$$

$$h = 30 \text{ ft.}$$

$$\Delta P = 7.64 \times \left(\frac{1}{499.67} - \frac{1}{534.67} \right) \times 30$$

$$\Delta P = 7.64 \times (0.0020 - 0.00187) \times 30$$

$$\Delta P = 0.03 \text{ in. w.g.}$$

Alternate Equation:

Stack pressure equation can also be expressed in terms of density:

$$\Delta P_s = (\rho_o - \rho_i) g (h - h_{neutral}) = \rho_i g (h - h_{neutral}) \frac{T_i - T_o}{T_o}$$

Where,

- ΔP_s = Pressure difference due to stack effect, psi
- ρ = Density of air, lb_m/ft³
- g = Gravitational constant = 32.17 ft./s²
- h = Height of observation, ft.
- $h_{neutral}$ = Height of neutral pressure level, ft.
- T = Absolute temperature, °R

(Subscripts i = inside and o = outside)

Example:

Consider the same example of a 30-foot high atrium with the inside and outside conditions of 75°F and 40°F, respectively. The hydrostatic pressure difference can be determined from the following equation:

$$\Delta P_s = (\rho_o - \rho_i) g (h - h_{neutral}) = \rho_i g (h - h_{neutral}) \frac{T_i - T_o}{T_o}$$

The density can be determined according to the ideal gas law:

$$\rho = \frac{P}{RT}$$

Where,

- R = Specific gas constant for dry air = 53.35 ft. lb_f./lb_m
- T = Absolute temperature, R
- P = Absolute pressure assumed to be 14.7 psi

Determining the values at 40°F:

$$\rho_o = \frac{P}{R T_o}$$

$$\rho_o = \frac{14.7 \text{ lb}_f / \text{in}^2 (144 \text{ in}^2 / \text{ft}^2)}{53.35 \text{ ft lb}_f (40^\circ\text{F} + 459.67 \text{ R})}$$

$$\frac{\text{lb}_m \text{ R}}{\text{lb}_m \text{ R}}$$

$$\rho_o = 0.0794 \text{ lb}_m / \text{ft}^3$$

$$\rho_i = \frac{P}{R T_i}$$

$$\rho_i = \frac{14.7 \text{ lb}_f / \text{in}^2 (144 \text{ in}^2 / \text{ft}^2)}{53.35 \text{ ft lb}_f (75^\circ\text{F} + 459.67 \text{ R})}$$

$$\frac{\text{lb}_m \text{ R}}{\text{lb}_m \text{ R}}$$

$$\rho_i = 0.0742 \text{ lb}_m / \text{ft}^3$$

$$\rho_o - \rho_i = 0.0052 \text{ lb}_m / \text{ft}^3$$

$$\Delta P_S = (\rho_o - \rho_i) g (h - h_{\text{neutral}})$$

$$\Delta P_S = 0.0052 \text{ lb}_m / \text{ft}^3 \times 32.2 \text{ ft} / \text{s}^2 \times 30 \text{ ft}$$

$$\Delta P_S = 5.023 \text{ lb}_m \text{ ft} / \text{s}^2$$

Convert 5.023 lb_m ft / s² to lbf

$$5.023 \frac{\text{lb}_m \cdot \text{ft}}{\text{s}^2} \times \frac{1 \text{ lbf}}{32.2 \frac{\text{lb}_m \cdot \text{ft}}{\text{s}^2}}$$

$$\Delta P_S = 0.156 \text{ lb}_f / \text{ft}^2$$

$$\Delta P_S = 0.156 \text{ lb}_f / \text{ft}^2 (0.1935 \frac{\text{in. w.g.}}{\text{lb}_f / \text{ft}^2})$$

$$\Delta P_S = 0.03 \text{ in. w.g.}$$

Neutral Pressure Level (NPL)

The location of NPL is an important parameter in calculating the pressure difference. It is difficult to know the location of the h_{neutral} (NPL) at any one moment, but there are some general guidelines. According to ASHRAE, 1989, the NPL in tall buildings can vary from 0.3 to 0.7 of total building height. In houses with chimneys, it is usually above mid-height, and vented combustion sources for space heating can move the NPL above the ceiling.

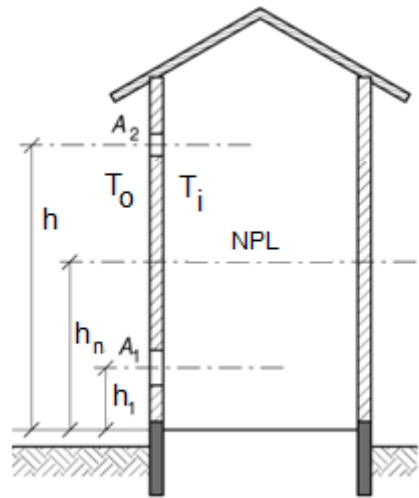

The height of the neutral pressure level, can be altered by changing the relative sizes (and/or number) of the upper and lower openings. If the upper opening is **increased** relative to the lower one, the neutral pressure level will rise. Conversely, larger openings towards the lower level will cause this height to fall.

Airflow caused by Stack Effect

The rate of flow induced by thermal force is given by the following equation:

$$Q = C * K * A * \sqrt{h * [(T_i - T_o) / T_i]}$$

Where,

- Q = Air flow, ft^3/min
- A = Free area of inlets or outlets (assumed equal), ft^2
- h = Height from inlets to outlets, ft .

- T_i = Indoor air temperature, °F
- T_o = Outdoor air temperature, °F
- C = Constant of proportionality = 14.46
- K = 65% or 0.65 for effective openings (50% or 0.50 for unfavorable conditions)

From a design perspective, there are three variables that will affect the rate of stack-effect ventilation:

1. The area of openings (inlet, outlet, and stack size, with the smallest of these three areas ruling);
2. The difference in elevation (height) between the inlet and the outlet; and
3. The difference in air temperature between the inlet and outlet.

Of these three variables, the areas and the height are most amenable to architectural decision making. Although the temperature difference can be modified through design decisions (location of inlet, solar augmentation, and the like), it is probably a less controllable variable as it fundamentally relies on weather conditions (climate).

Substituting the values for C and K , the equation reduces to:

$$Q = 9.4 * A * \sqrt{h * [(T_i - T_o) / T_i]} \quad (\text{for effective openings})$$

$$Q = 7.2 * A * \sqrt{h * [(T_i - T_o) / T_i]} \quad (\text{for unfavorable conditions})$$

When $T_o > T_i$, replace the denominator in the equation with T_o .

Assumptions:

1. There is no significant building internal resistance.
2. The equation is valid for temperatures T_i and close to 80°F.

COMBINED WIND AND THERMAL EFFECT

The actual flow in a building results from the combined effect of thermal and wind forces. The two forces may either oppose or reinforce each other, depending on the direction of the wind and on whether the internal or the external temperature is

higher. When acting simultaneously, the rate of air flow through the building may be computed by the following equation:

$$Q = (Q_w^2 + Q_s^2)^{1/2}$$

Where,

- Q = Resultant volume of air flow, cfm
- Q_w = Volume of air flow due to wind force, cfm
- Q_s = Volume of air flow due to thermal force, cfm

The overall airflow could be enhanced, if both stack and wind pressure drivers work in the same direction, i.e. have the same sign (-/+). If they work irreconcilably, i.e. have different signs (-/+), the airflow will decline and might stop completely as a result of their equality. It is seen that even when the two forces are nearly equal in magnitude, and operate in the same direction, the resulting air flow is about 40 percent greater than that produced by either force acting independently. This percentage decreases rapidly as one force increases over the other.

The figure below illustrates the pressure gradient and airflow patterns for each airflow driver and their combination.

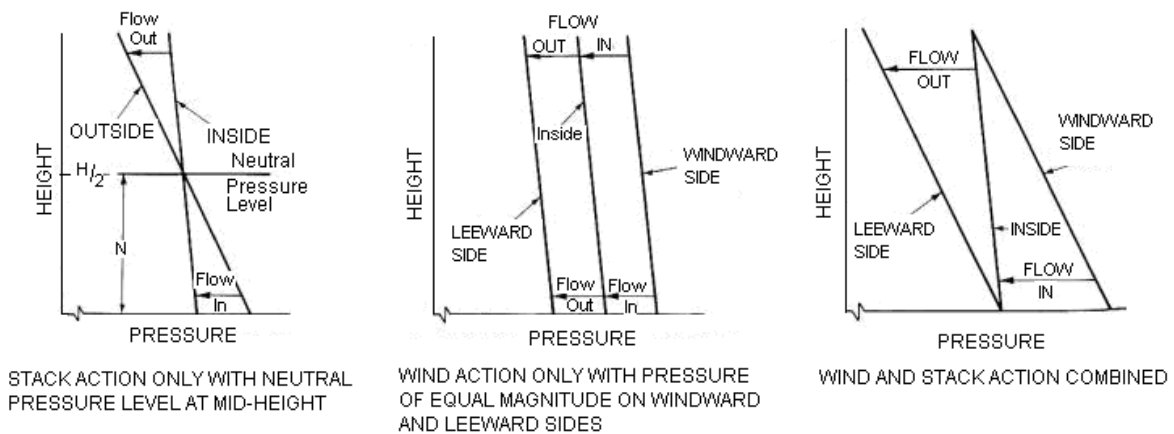

Combined effects of wind and thermal forces

(Figure Source: ASHRAE Handbook Fundamentals, 2005)

The relative importance of the wind and stack pressures in a building depends on the building height, internal resistance to vertical air flow, location and flow resistance characteristics of envelope openings, local terrain, and the immediate shielding of the building structure.

Stack effect acting over the entire height of the building occurs in all buildings, but the magnitude of the effect is reduced significantly in buildings that are well sealed between floors. It is not possible to reduce the building height stack effect completely because even in well-sealed buildings there is some airflow into the stairway and elevator shafts through imperfect seals, as well as airflow through openings and closing of doors. The building height stack effect is greatest in buildings with large airflow openings between floor levels such as in buildings with each floor connected to a central atrium.

In buildings with combined stack and wind effects, stack pressure differences are reduced with increasing height, moving towards the height of the natural pressure plane. However, this effect may be partially compensated for by the increasing wind pressure at upper levels due to increasing wind speed with height.

UNCONTROLLED VENTILATION

Air inevitably enters a building through pores in materials, cracks, holes or other interstices around windows and doors into a building. The uncontrolled introduction of outside air into a building is called infiltration. Airflow characteristics vary according to the size and shape of the opening. Long paths with small cross-sections may exhibit laminar flow and have a resistance proportional to the velocity. Larger holes may act like orifices with flow resistance varying with the square of the velocity.

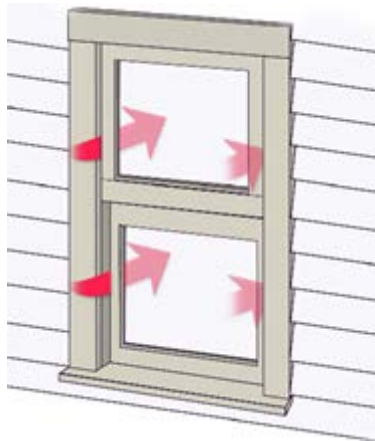

Air infiltration not only affects the building pressurization but may also distort the intended air flow pattern. Understanding infiltration requires understanding the pressures that cause the flow and the flow characteristics of the openings in the building shell.

Estimation of infiltration rates

Usually, different kinds of openings contribute to the total leakage. It is not practical to identify, measure, or calculate each individually. Overall flow rates for the aggregate of openings take the following form:

$$Q = C * (\Delta P)^n$$

Where,

- Q = Volume flow rate of air, ft³/min
- C = Flow coefficient (volume flow rate per unit length of crack or unit area at a unit pressure difference)
- ΔP = Pressure difference, in-wc
- n = Flow exponent ranging from 0.5 to 1.0, normally 0.65

Air Leakage from Wind Pressure

Building air leakage area is a physical property of a building determined by its design, construction, seasonal effects, and deterioration over time. The larger the air leakage area, the larger will be the infiltration rate. However, no simple relationship exists between a building's air tightness and its air exchange rate, although some empirical methods have been developed to estimate the values.

The designer should first identify the leakage paths, estimate their size and then calculate the airflow that will be needed to create and maintain the required pressure difference across the leakage paths. A constant air supply of this magnitude has then to be delivered to the space it is designed to pressurize. This is the condition when all the doors are closed. To determine the amount of air required to maintain a specified pressure differential, the following equation is applied:

$$A_L = \frac{Q}{E \cdot \left(\frac{2 \Delta P}{\rho}\right)^{0.5}}$$

Where,

- Q = Volumetric flow rate, ft³/min
- A_L = Free area of inlet openings, ft²

- ΔP = Pressure difference of air entering and exiting the building, in-wc
- E = Discharge coefficient
- ρ = Density of air, lb_m/ft³

The discharge coefficient depends on the geometry of the flow path, as well as turbulence and friction. As per ASHRAE HVAC Application handbook-1995, the flow coefficient is generally in the range of 0.6 to 0.7.

Normally, infiltration may be lessened by reducing the air leakage of the building shell (for example, by increasing air tightness) and reducing the surface pressures driving the air flow (for example, through changing the landscaping in the vicinity of the building).

In Summation

Natural ventilation is one of the major design features of recent as well as traditional sustainable buildings. Thermal buoyancy is the main design consideration in terms of the driving force for natural ventilation of many types of buildings such as those incorporated with atria due to the unpredictable nature of wind. However, average wind speeds often produce stronger effects on natural ventilation than does buoyancy. The external wind can assist or oppose the internal buoyancy-driven flow depending on the building configuration and wind velocity. The internal air flow and resulting temperature/pollutant distribution in spaces with buoyancy-driven natural ventilation would therefore be complicated by the external wind.

SECTION - 2: NATURAL VENTILATION PRINCIPLES

The starting point in ventilation design is to determine how much ventilation air is required, and for what purposes. In North America, the most widely accepted standard for designing ventilation systems to achieve acceptable indoor air quality in buildings is ASHRAE Standard 62-2007, Ventilation for Acceptable Indoor Air Quality. For indoor air quality, the requirement for ventilation is based on the number of occupants and is 15 cfm per person. This design capability is needed at all times in winter and summer. This section outlines the basic principles underlying natural ventilation, and explains how best to proceed with a specific design.

The ventilation principles used in the building to exploit the natural driving forces can be divided into three types:

1. Single-sided ventilation
2. Cross-ventilation
3. Stack ventilation

The ventilation principle indicates how the exterior and interior airflows are linked, and hence how the natural driving forces are utilized to ventilate a building. Furthermore, the ventilation principle gives an indication on how the air is introduced into the building, and how it is exhausted out of it. Infiltration through the building envelope can also play a certain role, depending on the air-tightness of the building envelope. However, this form of ventilation is usually both unintended and unwanted.

SINGLE- SIDED VENTILATION

Single sided ventilation relies on airflow through openings on only one side of an enclosed space. The air enters from one opening and leaves from the same opening or from another opening in the same wall. Refer to the figure below.

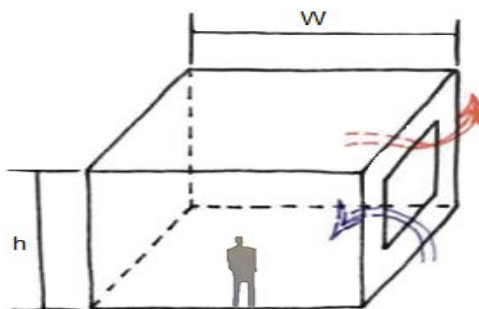

With single ventilation opening in the room, the main driving force for natural ventilation is wind turbulence. Compared to other strategies, lower ventilation rates are generated and the depth of penetration of the airflow into the space is limited. If more than one ventilation opening is provided and openings are located at different heights, the ventilation rate can be enhanced by the stack effect. Stack induced flows increase with the vertical separation of openings. If more than one ventilation opening is provided and openings are separated by a horizontal distance, the ventilation rate is enhanced by the flow from one window to the other due to the difference in wind pressure coefficients at the location of each window.

Advantages:

- Single sided ventilation is popular because openings are located on only one face of an enclosed space.

Disadvantages:

- No defined exit route for air;
- Net driving forces may be small resulting in poor ventilation;
- Not suitable for deep plan spaces. Depth of penetration is restricted to approximately 2.5 x ceiling height.

Single sided natural ventilation should be avoided!

CROSS VENTILATION

Cross ventilation relies on airflow between ventilation openings on opposite sides of a space. Simply, the air enters from one opening (in the windward wall) and travels across the space to leave from another opening in the opposite side (in the leeward wall). As the air moves across a cross-ventilated space, it picks up heat and pollutants. Refer to the figure below.

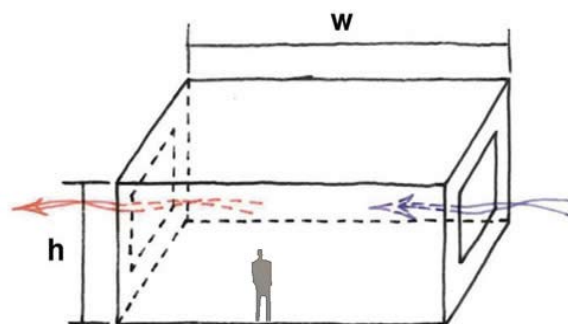

Cross ventilation can be considered as the most effective technique that can grant a consistent large airflow with deep air penetration across the ventilated space. The airflow in the cross ventilation is a wind driven airflow, unless a difference in height between the inlet and outlet openings within the same wall is provided, and thus thermal buoyancy starts to play a significant role. The contribution from thermal buoyancy depends on the temperature difference between the inside and the outside, the vertical distance between the openings, and the area of the openings. The greater vertical distance between the openings, and the greater temperature difference between the inside and the outside, the stronger is the effect of the buoyancy.

Advantages:

- A high rate of ventilation is possible under favorable weather conditions;
- It can be used in relatively deep-plan spaces with two or more perimeter walls containing windows that can be opened;
- For equivalent size of openings, cross flow covers a larger zone than the single-sided openings.

Drawbacks:

- Effective cross-ventilation requires a relatively clear path for air to flow across the space;
- Inappropriate window design and positioning may result in disruptive drafts;
- Design of interior layout etc. can be more complex than for single sided solutions.

Cross flow designs form the basis of best practice in natural and mixed mode ventilation systems. The majority of designs are based on cross flow.

STACK VENTILATION

Stack ventilation is driven through the building by thermal buoyancy. The warm air inside the building is less dense than cooler air outside, and thus will try to escape from openings high up in the building envelope. The cooler denser air will enter through lower openings in the building envelope. The process will continue if the air entering the building is continuously heated, typically by casual or solar gains.

Stack ventilation occurs naturally whether we design it or not, and has been consciously used for centuries in traditional and vernacular buildings ranging from Indian tepees to churches. It requires a minimum difference of 3°F between indoor and outdoor temperatures.

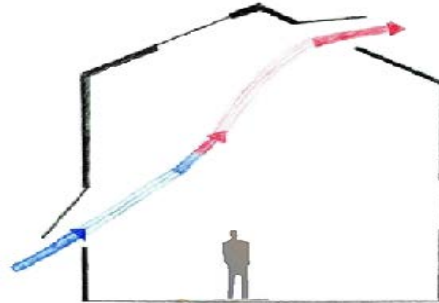

A key consideration when designing for Stack Ventilation is the location of inlet and outlet openings. The total amount of heat removed from a space is proportional to the height differential between the openings. In general, the greater the height difference between the inlet and outlet openings, the greater the volume of air pulled through the space, and the cooler the interior temperatures.

Natural Ventilation Design Recommendations

The appropriate ventilation strategy must be considered at the concept design stage. It can be extremely difficult to incorporate natural ventilation in a building when fundamental design choices have already been made. For example, deep-plan and light-weight construction can render a successful natural ventilation strategy impossible. It is therefore important to involve the ventilation designer at the earliest design stage. The table below highlights key design features which can either make natural ventilation successful or more difficult.

Key design features affecting the success of natural ventilation

Success factors	Problem issues
Narrow plan	Deep plan
Two-sided façade	Single-sided façade
High ceilings	Low ceiling heights

Thermally heavyweight construction	Thermally lightweight construction
Controlled internal gains	High incidental heat gains – particularly solar and from computer equipment
Low external noise levels and controlled indoor ambient noise levels	High external noise levels and uncontrolled indoor ambient noise levels

The above table shows factors with the greatest impact on designing for natural ventilation, but the designer should also bear in mind that ventilation needs to provide good indoor air quality in summer and winter, and in a controllable and energy-efficient manner. Failure to be aware of these issues and focusing solely on one aspect can compromise the design. For example, a design that focuses mainly on the avoidance of overheating and provides large openable windows may not allow for the fine control of ventilation required in winter to provide adequate draught-free ventilation. In this case it may be better to provide a separate ventilation opening to meet the winter ventilation requirement. Using large windows might also lead to lower airtightness (unless they are well sealed when closed) as well as to draughts and infiltration energy loss.

General Recommendations

Single-sided Ventilation:

- Single sided ventilation is generally effective for room depths NOT more than 2.5 times the height of the room.
- The ventilation opening area should be between 5 to 10% of the room’s floor area.

This technique is more suitable for moderate climates and not effective in hot climates.

Cross Ventilation:

- Cross ventilation is the most suitable technique for ventilating deep-plan buildings. The depth of the room can be up to 5 times the height.

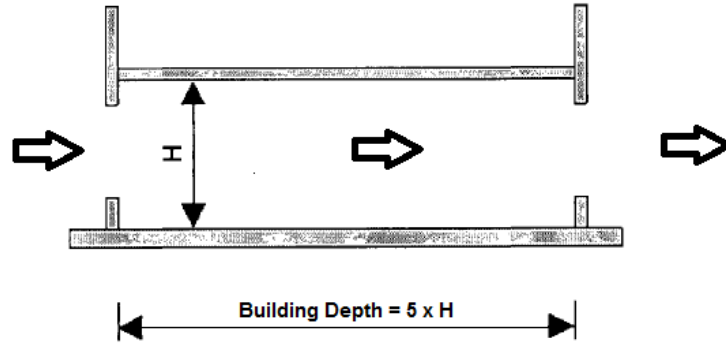

- The opening area required is approximately 2% of the floor area (1% on each side of the space).

Stack Ventilation:

- Stack ventilation can be effective across a width of 5 times the floor-to-ceiling height from the inlet to where the air is exhausted to the stack.

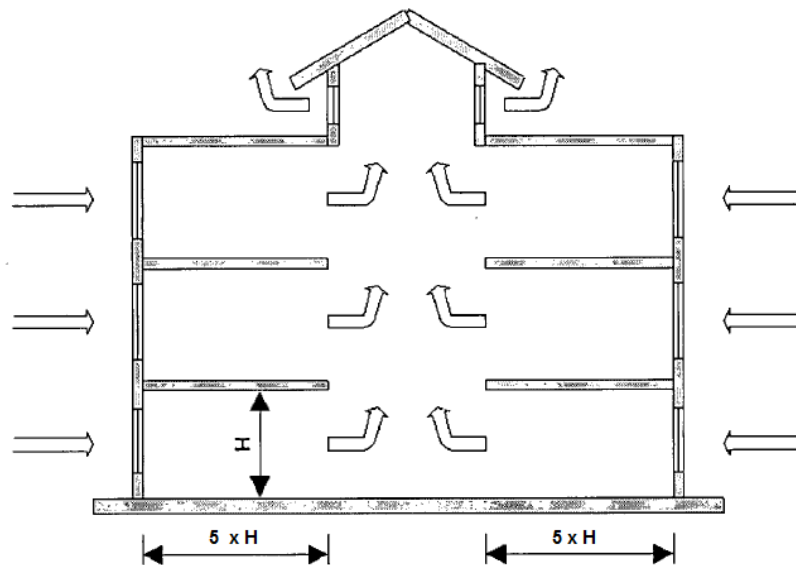

This rule is based on a building with a large stack or atrium running down the center of the building and spaces on either side of the stack having a maximum depth limit of 5 times the floor-to-ceiling height of individual levels. For example, a building with floor-to-ceiling height of 10 ft. on each level would be limited in depth to 50 ft. between the perimeter of the building and the stack. This results in a maximum depth building of 100 ft. plus the depth of central stack or atrium.

- The stack effect is quite weak, and therefore openings must be large, to minimize resistance. Ideally, the outlet opening should be greater in size than the area of the inlet openings; the larger the ratio between the size of the outlet and inlet openings, the greater the pressure difference and the more cool air that can be pulled into the space.
- The pressure difference within the stack varies with height resulting in diminishing air flows from spaces opening on to the stack, as their height above ground floor increases.
- Guidelines for locating inlet and outlet openings:
 - Residential spaces: a minimum of 10 feet apart in height (H).
 - Commercial spaces: a minimum of 15 feet apart in height (H).

The greater the height between openings, the greater shall be the air movement. Locate inlet openings (h) below the height of an occupant's upper body; i.e. 2½ ft. to 4½ ft. above finished floor.

Three Rules of Thumb for Acceptable Indoor Air Quality

Three rules of thumb for achieving acceptable ventilation rates for indoor air quality can be derived from the prescriptive requirements for naturally ventilated buildings laid out by ASHRAE Standard 62 – 1999. The Standard suggests adherence to the following requirements for size and location of natural ventilation openings:

1. Naturally ventilated building spaces should be limited to a depth of 25 ft. from the exterior wall or roof openings.
2. Operable areas in exterior walls and roofs should be at least 4% of the net occupiable floor area.
3. Interior partitions or walls between naturally ventilated spaces and outside ventilation openings should have permanent openings of at least 8% of the floor area of the interior portion of the space, with a minimum opening area of 25 ft².

DETERMINATION OF VENTILATION RATES

The objective of designing a ventilation system is to determine the ventilation rate to maintain an acceptable temperature as well as acceptable moisture and contaminant

levels inside a building. To determine the ventilation rates, heat and moisture balance calculations have to be performed on a building envelope. Three methods can be used:

1. Maximum allowable concentration of contaminants
2. Heat dissipation
3. Air change method

Maximum allowable concentration of contaminants

The concentration of carbon-dioxide (CO₂) in a room is often used as a guide to the quality of indoor air. CO₂ is a product of human respiration and combustion. Indoor CO₂ levels in a space are affected by a number of factors including:

- The number of occupants in the room;
- The activity levels of occupants;
- The amount of time occupants spend in the room; and
- The ventilation rate.

Indoor concentrations above about 1,000 parts per million (ppm) CO₂ indicate that IAQ is unacceptable. The mass balance equation can be used to describe the steady-state conditions of contaminant concentrations and ventilation rate.

$$C_i = C_o + F / Q$$

Where,

- C_i = Maximum allowable concentration of contaminants, ppm
- C_o = Concentration of contaminants in outdoor air, ppm
- F = Rate of generation of contaminants inside the occupied space, cfm
- Q = Ventilation rate, cfm

Example:

Consider a lecture classroom of 1000 sq.-ft with a design population of 80. ASHRAE 62 “Standard for Ventilation” requires 15 cfm of outdoor air per person for this space.

Therefore, the classroom must receive 1200 cfm of outdoor air (15 cfm / person × 80 people).

Assuming the CO₂ generation rate of 0.0106 cfm per person and the design ventilation rate of 15 cfm per person, the resulting indoor-to-outdoor CO₂ concentration differential will be 700 ppm.

$$C_I - C_O = F / Q$$

$$C_I - C_O = 0.0106 / 15 = 0.0007 \text{ [or 700 ppm]}$$

Ventilation Rate for Heat Dissipation

The ventilation rate required to remove heat from an occupied space is given by:

$$Q = h / (60 * C_P * \rho * \Delta T) = h / (1.08 * \Delta T)$$

Where,

- Q = Ventilation rate, cfm
- h = Heat removed, Btu/hr.
- ΔT = Indoor outdoor temperature difference, °F
- C_P = 0.245 Btu/lb./°F
- ρ = 0.075 lb./ft³

Example:

Determine the ventilation rate for an electrical room having a heat gain of 10 kW. Assume average outdoor air temperature of 90°F. Assume the indoor temperature to be maintained is 80°F.

Solution:

The British power unit for thermal energy is "BTU per hour".

The conversion rate for Watts is 3.414, so you get 10 x 1000 x 3.414 = 34140 Btu/hr.

$$Q = 34140 / [1.08 * (90 - 80)]$$

$$Q = 3161 \text{ cfm}$$

Ventilation Rate on Air Change Method

The rate of air flow is the number of times the total room volume of air is changed per hour. The ventilation rate can be expressed as:

$$Q = V \times \text{ACH} / 60 \text{ min/hr.}$$

Where,

- Q = Ventilation rate, cfm
- V = Volume of space, ft³
- ACH = Air change per hour

In this equation, Q is the volume flow rate of air being calculated, and ACH is the number of air changes per hour expected, based on the application and the type of construction. Most professional institutes and authorities have set up recommended ventilation rates (expressed in air change per hour) for various situations.

Building / Room	Air Change Rates	Building / Room	Air Change Rates
All spaces in general	min 4	Offices, public	3
Auditoriums	8 - 15	Offices, private	4
Cafeterias	12 - 15	Restaurants	8 - 12
Kitchens	15 - 60	School Classrooms	4 - 12
Nightclubs	20 - 30	Supermarkets	4 - 10
Medical Centers	8 - 12	Warehouses	2
Medical Clinics	8 - 12	Waiting rooms, public	4

Example:

Office room is 10 ft. long and 10 ft. wide. The height is 9 ft. and the recommended ACH is 4. Calculate the airflow.

Volume of the room = 10 x 10 x 9 = 900 ft³

Q = 900 x 4/60

Q = 60 cfm

NATURALLY VENTILATED BUILDING DESIGN

A few important rules of natural ventilation and some of the guidelines for designing buildings for best possible utilization of outdoor wind indoors are highlighted below:

Site location

The site landform could be flat, sloping or undulating (mounds, etc.). The slopes and depressions could create significant variations in the airflow and air temperatures across the site. Due to the different exposures to the solar radiation between the day and the night times, the airflow could be reversed in mountainous regions in particular. During the daytime, the air in the valley is heated up and moves up along the slopes where the low pressure area is formed. During night time, the cool air tends to fall down the hill under the effect of its high density and settles into the depression creating a cold reservoir.

For the wind driven airflow, the slopes that face the windward direction experience much higher wind speed than those that face the leeward direction. Also, the highest airspeed could be found at the crest of the slope. In narrow valleys this phenomenon can create very strong winds up along the valley floor during the day and down the valley at night. By proper location and control of openings, this phenomenon can be used for ventilation during daytime and for free night cooling.

- In hot-arid climates, the best location is at the bottom of the slope oriented towards the East, in order to get the maximum exposure to the cold flow during the night along with providing a minimal exposure to the afternoon sun.
- In hot-humid climates, the best location is at the crest of the slope oriented towards the East, in order to maximize the exposure to the wind and minimize the exposure to the afternoon sun.
- In the cold climates, the best location is low on a south facing slope (North facing in south hemisphere) in order to maximize the exposure to solar radiation, provide wind protection and avoid a cold reservoir at the bottom of the valley.
- In temperate climates, the best location is at the middle to upper part of the slope in order to provide good exposure to the sun and wind as well as provide protection from the high wind speeds at the crest.

Heat Sinks

The availability of heat sinks such as large bodies of water (sea, river and lake) near the building site could create local airflow patterns over the site, which in turn affect the natural ventilation performance in the surrounding buildings.

The large heat capacity of water prevents it from heating or cooling as fast as land. Thus, during the day the air is hotter over land than over water. The resultant pressure differences generate sea breezes. At night the temperatures and air flows reverse. In the late afternoon and early morning, when the land and sea are at the same temperature, there is no breeze.

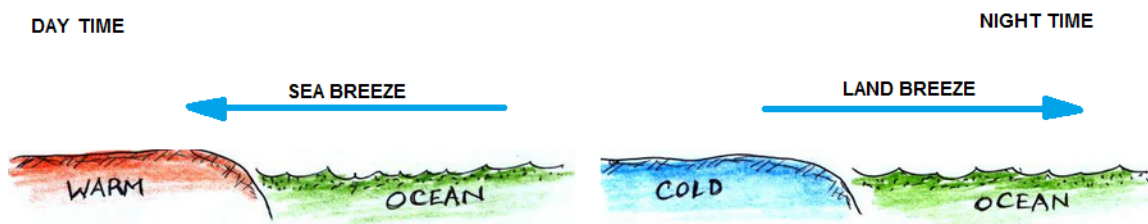

Building on the sites near the large water bodies is more suitable for hot-dry climates as water bodies produce a cool breeze and provide cooling through evaporation.

Site Layout

The site layout and urban form has a significant role in wind induced ventilation. Four main urban forms could be identified:

1. **The compact form:** The buildings are arranged in a neat and orderly form in a smaller interval space between dwellings. It responds favorably to both hot-dry and cold-dry climates.
2. **The disperse form:** Consists of low-rise detached buildings with wide spaces in between. It is preferable in hot-humid climate where air movement and ventilation is required. It can also exist in cold-humid climates with some controllable features for winter wind protection.
3. **The clustered form:** Consists of small assemblies of buildings, which are built very closely to each other. It responds favorably to both hot-dry and cold-dry climates.
4. **The combined form:** It is a combination of the different aforementioned forms.

Shape of the Building

The form of the building can have a significant influence on the way a natural ventilation system is able to work.

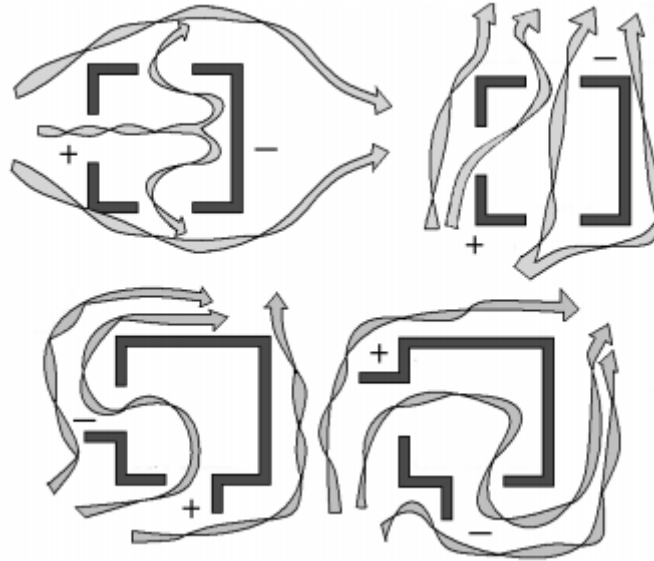

Note the key facts:

- Naturally ventilated buildings are relatively narrow in plan. The maximum width that one could expect to ventilate naturally is estimated as 25 ft.
- The height and shape of a building and the angle of the roof are important. For the best ventilation performance, the building aspect ratio (length/width) should be kept low.
- For simple rectangular shapes, the long façade should face the direction of the summer wind.
- The irregular shapes of buildings can have large variations in pressure and can enhance natural ventilation.
- Single story deep plan buildings can be naturally ventilated through roof outlets. Multi-story deep plan buildings shall consider atriums in the middle.

Building Spacing and Arrangement

Arrange buildings to provide for good air flow around all structures.

- A linear arrangement of homes lined up parallel to the wind direction creates poor airflow.
- A linear arrangement of homes lined up at an angle to the wind direction provides good airflow.
- A staggered arrangement of homes creates good airflow regardless of wind direction.
- Spacing buildings by a distance of at least five times the height of the upwind building provides greater natural ventilation opportunities for the downwind building.

Building Orientation

The building orientation with respect to wind direction significantly affects natural ventilation performance. Since the building orientation is mostly associated with the street orientation, the optimum ventilation potential could be obtained in an oblique orientation.

- The optimum angle, which provides the best air circulation inside spaces, could be obtained by orienting the inlet 45° to the prevailing wind. Inlet openings facing the incoming wind at 90° provides the maximum airflow.
- The long façade of the building and the majority of the openings should be oriented with respect to the prevailing summer breezes i.e., north-south orientation for westerly wind.

Landscaping

Landscaping has an important function in controlling the air movement around buildings for optimum natural ventilation. Vegetation can create areas of higher wind velocities by deflecting winds or funneling air through a narrow passage (Venturi effect). The presence of vegetation at the site also greatly helps in improving the air quality by removing dust particles, absorbing carbon dioxide and producing oxygen into the air.

Trees with large foliage mass having trunk bare of branches up to the top level of window, deflect the outdoor wind and promote air motion in the leeward portion of the buildings.

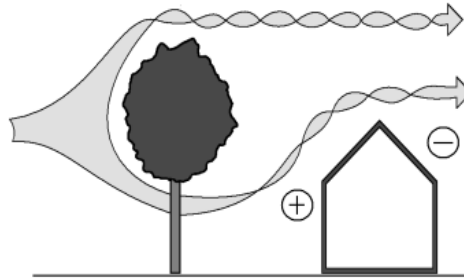

Inlet – Exhaust Arrangement

At least two openings on opposite sides or ends of the buildings are preferred for air distribution within the structure and to avoid short-circuiting of airflow. Note the key facts below:

- Greatest flow per unit area of openings is obtained when the inlet openings are located on the windward side at a low level, and outlet openings on the leeward side. Ideally, the outlet openings should be located on the opposite walls to provide cross ventilation.
- Greatest flow per unit area of openings is obtained when the openings are oriented perpendicular to the incident wind.
- Where direction of the wind is quite variable, the openings may be arranged as far as possible such that there is approximately equal area on all sides. When the openings are at 45° to the wind direction, there is a better average indoor velocity and better distribution.
- Inlet openings (as far as possible) should NOT be obstructed by adjoining buildings, trees, sign boards or other obstructions or by partitions inside in the path of air flow. These elements should be located at least 25 feet away from the inlet openings of the building. However, air motion in the leeward part of the building can be enhanced by planting a low hedge at a distance of 6 ft. from the building.
- Keep vertical distance between the inlet and exhaust openings as high as possible to take advantage of the stack effect. If appropriate, horizontal openings near floor level are more effective than vertical openings for ventilation purposes.

Size of openings

The opening size controls both the ventilation rate and air velocity within the interiors. The general rule of maximizing the natural ventilation effectiveness is to have inlet and outlet openings as large as possible.

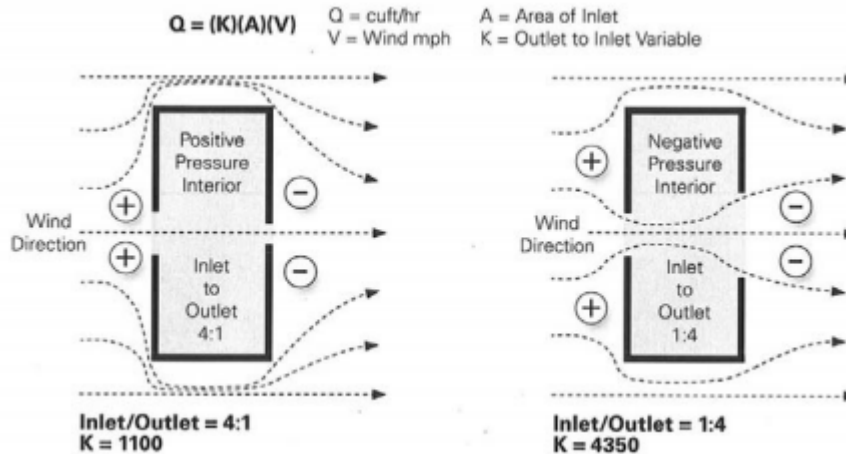

Key Facts:

Greatest flow per unit area of openings is obtained when:

- The inlet is small and the outlet is large by at least 25%.
- The inlet window height is limited to 3.6 ft. and the inlet width is up to two-thirds of the wall width.

Vertical Shafts and Staircases

Vertical shafts and open staircases may be used to increase and generate stack effect.

Enclosed staircases used to take advantage of the stack effect ventilation should be designed such that their function as fire exits is not compromised. Also, enclosed staircases intended for evacuation during a fire should not be used for ventilation.

Architectural Treatments

To increase the cooling effectiveness of natural ventilation techniques, especially on sites with low outdoor air velocity and variable wind directions, it is possible to incorporate architectural elements such as wing walls, parapets, overhangs, awning windows, eaves, porches etc. into the building design. These elements create

positive and negative pressures to induce cross ventilation and protect the openings from rain while minimizing excess heat gain from direct sunlight.

We will discuss more of architectural elements in the next section.

SECTION - 3: ARCHITECTURAL ELEMENTS

Specialized architectural features are often introduced to the building design to enhance and aid natural ventilation performance. The most important elements are openings in the façade, windows, wind towers, wind scoops, chimneys, double façades, atria, embedded ducts, etc. An overview over the various elements is provided below together with the ventilation principle the individual element is most likely to be associated with. A description of the advantages and drawbacks of the individual element is included.

WINDOWS

Good window design is vital to ensure effective natural ventilation; different window types have varying ventilation characteristics, acoustic properties and weather protection. Windows (together with doors and roof lights) have the advantage of being easily shut by the user and are easy to seal effectively.

Their performance can be compromised by blinds, shutters or louvers used for solar control or blackout purposes and this needs to be taken into account when selecting the window type. Some of these features are described in Table below:

Characteristics of different window designs

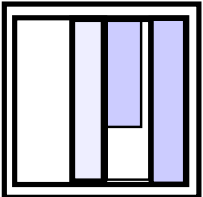
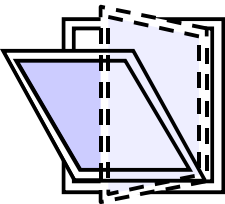
Window Type	Airflow	Ventilation Effectiveness	Comments	Position of Opening
Horizontal sliding sash	Very good	Medium	No obstruction of internal blinds or external paths – can be draughty	
Tilt and turn	Good	Medium	Control is complex. Can reflect noise into classroom and turn function can be difficult with blinds – good at providing draught free winter ventilation	

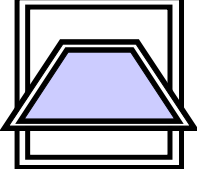
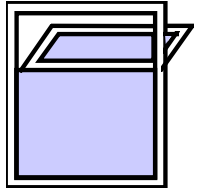
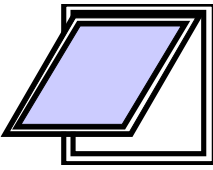
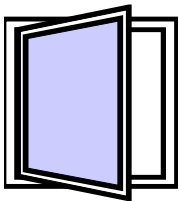
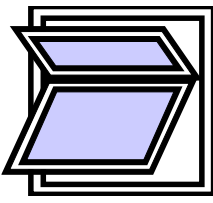
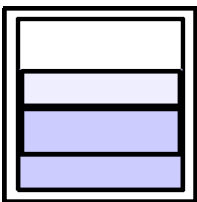
Centre pivot	Very good	Good	Can obstruct blinds and prevent glare control for VDU use and reflect noise into classroom	
Bottom hung inward opening fan light	Medium	Very good	May obstruct blinds. Can provide good control of external noise from ground level	
Top-hung outward opening	Good – but less so if restricted opening	Good	Can reflect noise into the room. Can pose a hazard if opening over a pathway or playground	
Side-hung casement	Good	Poor	Poor security when open and rain can enter. Can pose a hazard if opening over a path or playground	
Upper fanlight and outward opening casement	Good	Very good	Good all round performance. Can pose a hazard if opening over a path or playground – possible rain ingress	
Vertical double sash	Very good	Medium	No obstruction of internal blinds or external paths.	

WIND SCOOPS

Wind scoop or wind catcher is designed to catch the wind at the area of greatest positive pressure and direct fresh air into the building.

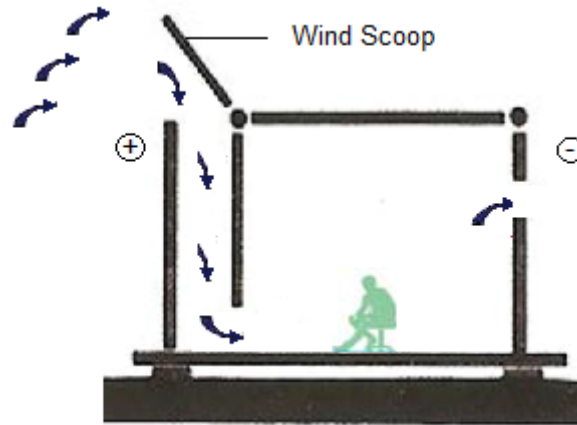

A wind scoop follows the same principals of a window; it allows ventilation and encourages breezes. A wind scoop is superior to a window for the reason that it brings cool air from roof top to a lower elevation and forces the warm air to escape from higher elevations. Scoop has to be multi-directional when the desired wind heavily changes its directions. At the angle of 30° (deviation away from the head-on wind), the scoop starts to become ineffective. At 50° it is completely ineffective, and starts to act as an exhaust.

Design:

The design of a wind scoop is very much a product of its environment. In order for a wind scoop to be effective, a substantial breeze must be present and also be relatively consistent in the same direction. It is possible to design and create a wind scoop that pivots and rotates for optimized air input, but simpler wind scoops are generally stationary. Specially designed wind catchers have openings all around, so that winds get scooped into the building from all directions, and some designs even help put out through the same fixture.



Applications:

They are particularly effective in large-volume buildings. Normally they are placed on the roof, even though it is possible to place them in the landscape some distance away with the supply air then being brought in via embedded ducts. Another important application is that they can offer a good alternative for buildings in which the facades are unsuitable for ventilation purposes due to noise infiltration, pollution or low air movement.

Limitations:

Wind scoops are limited by their environment. No matter how well they are designed, if adequate air flow is not present, the wind scoop will be ineffective. Another limitation is that wind scoops are only good at handling moderate temperatures. Much like a window, a wind scoop can only help so much without directly altering the incoming air. On a hot day, a wind scoop can make you uncomfortable.

WIND TOWERS

Wind towers are building elements designed to take advantage of the prevailing summer winds to cool the air and circulate it through the building. They can be placed on or next to the roof of the building, or as a separate structure. They often have openings on several sides and therefore these are able to both catch the wind and extract air from the building at the same time. The effectiveness of wind towers depends on producing the maximum pressure difference between the air inlet openings and the wind tower. The air movement around the building will determine the size and position of the tower and openings to maximize the pressure difference.

Tower height also affects the ventilation rate. The taller tower has stronger winds passing through it, creating a greater negative pressure.

Wind towers can be used in combination with wind scoops to create a system by which cool air is provided by wind scoops, and warm air is then extracted by wind towers. By collecting and extracting air at high levels, there will be a greater pressure difference between devices, producing more air flow through the building.

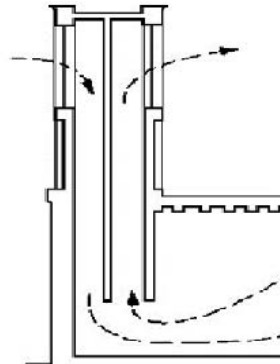
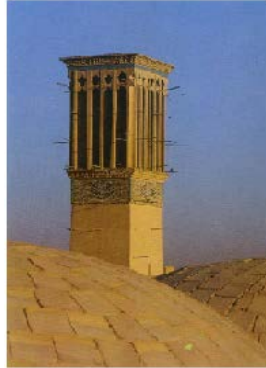

Design:

- In a wind tower, the hot air enters the tower through the openings in the tower, gets cooled, and thus becomes heavier and sinks down.
- The inlet and outlet of rooms induce cool air movement.
- In the presence of wind, air is cooled more effectively and flows faster down the tower and into the living area.
- After a whole day of air exchanges, the tower becomes warm in the evenings.
- During the night, cooler ambient air comes in contact with the bottom of the tower through the rooms.
- The tower walls absorb heat during daytime and release it at night, warming the cool night air in the tower.
- Warm air moves up, creating an upward draft, and draws cool night air through the doors and windows into the building.

Advantages:

- They can (be designed to) work independent of wind direction.
- They can protect the exhaust opening from rain and snow ingress.

Drawbacks:

- The system works effectively in hot and dry climates where fluctuations are high.
- A wind tower works well for individual units not for multistoried apartments.
- In dense urban areas, the wind tower has to be long enough to be able to catch enough air.

CHIMNEYS

Chimneys provide a means of generating stack ventilation and the essential requirement to provide increased buoyancy effect. Chimneys provide no functional purpose other than ventilation.

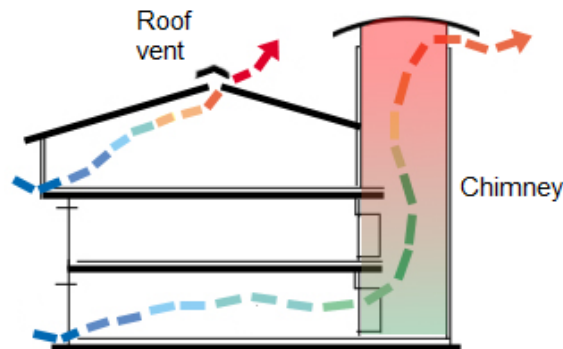

In the figure above, the fresh air is drawn at the lower heights and warm air exhaust through the chimney. It is possible to enhance the stack pressures by using solar chimney, in which glazed elements are incorporated into the chimney structure. Solar radiation enters the chimney through the glazing and is captured by absorbing surfaces. Heat is then released to the air by convection, promoting buoyancy. Care has to be taken to ensure that there is a net heat gain into the chimney during cooler weather. If this balance is not achieved, buoyancy will be reduced and the chimney will be less effective.

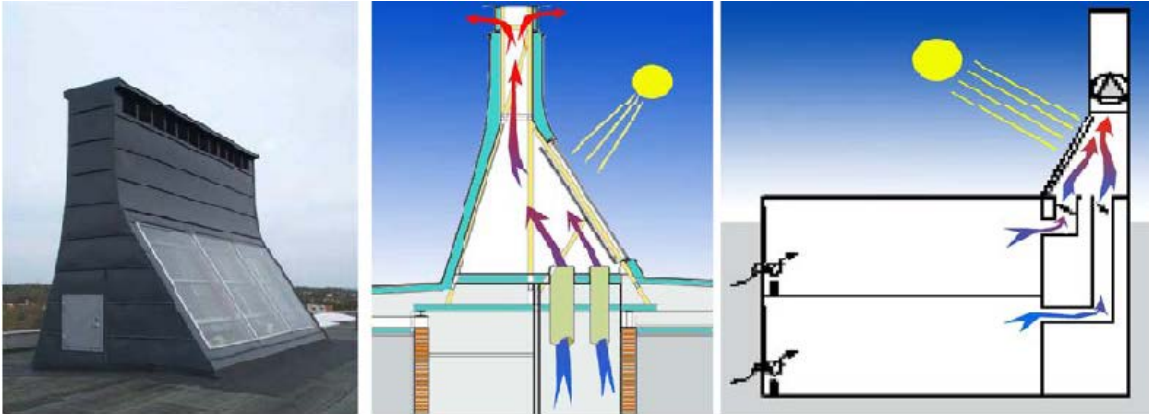

The chimney outlet should be located in a negative wind pressure zone. This negative pressure zone can be created by careful design of the roof profile and/or the chimney outlet. To provide adequate ventilation on very hot and still days, an extract fan can be installed in the shaft to pull air through the building. This should be designed so that the fan does not provide a significant resistance to air flow when the chimney is operating in its natural draught mode.

DOUBLE FACADES

A double façade system involves the “Thermo-siphon” effect, which has the same working principle as solar chimney. This requires additional second glazed envelope, which can create opportunities for maximizing daylight and improving energy performance. Over the height of a building, a significant temperature gradient can develop, particularly within the glazed layers of a double-skin façade. The superheated air then rises and is released by vents at the top of the façade. Air is vented from the interior spaces into the façade through automated vents in the inner skin.

Depending on the type of construction, a secondary glass layer can effectively lower the wind load on the window sashes and allow for regulated fresh air supply through flaps in the outer layer. The space between the two façade layers can be used for wind-protected natural ventilation. This feature is especially useful in high rise buildings, where strong winds often prohibit opening windows on higher levels in case of single façades.

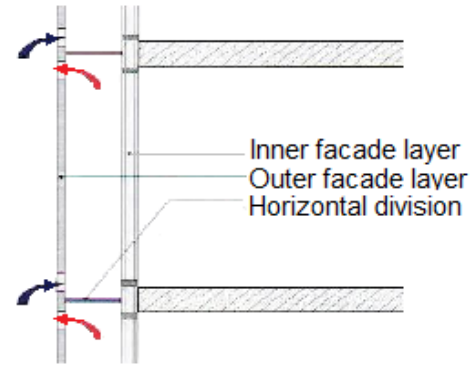
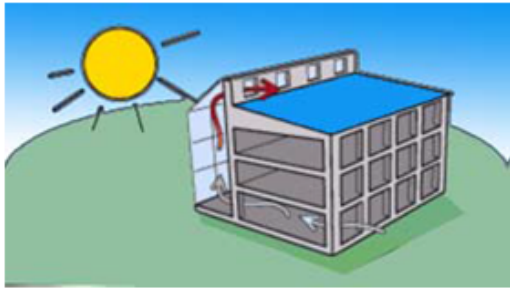

Advantages:

Double façades used for natural ventilation can be used as an outlet or inlet path in any of the three natural ventilation principles. They offer many advantages:

- The cavity is protected against wind and outdoor noise. Thus, open windows can be allowed irrespective of wind and noise from the outside, even in the upper floors of high-rise buildings.
- Solar shading devices are protected from wind when placed in the cavity.
- Solar preheating of the supply air is provided on sunny days, when the cavity is used as air supply path.
- Due to the protected environment in the cavity, transmission losses through the wall are reduced compared with an ordinary external wall. When used as a supply air path, some of the transmission heat losses through the wall will be captured by the inlet airflow in the cavity; thus, a heat recovery effect is provided.
- Due to the protected climate in the cavity, window surfaces in the rooms inside will be warmer, reducing cold downdrafts and asymmetric radiation.

Drawbacks:

- The space between the layers can easily overheat. Overheating, mostly on summer days, prevents or inhibits natural ventilation. On the other hand, the greenhouse effect can be used to preheat the fresh air supply, particularly during winter and the transitional seasons.
- In regions with extremely low winter temperatures, there is the added risk of condensate forming on the outer glass pane which can eventually freeze.

- Noise can be transferred between adjacent rooms by reflection in the glazed cavity surfaces.
- Cleaning of the cavity is important, especially when used as a supply air path. This implies higher operation costs than in the case of a normal facade.
- A double facade represents significantly higher construction costs than a normal facade. However, double facades are not usually built for ventilation purposes only, so the costs can be distributed over several other functions, e.g. daylight and visual amenity.

ATRIUMS

An atrium is a space with glazed roofs, typically in the middle of a deep plan building, providing daylight and visual amenity for the surrounding building spaces. It is a variant of the chimney ventilation principle. In fact, the same effect could be achieved by a central spine of chimneys. The essential difference is that it provides space for circulation and social interaction. And because it provides attractive, usable space, the location of the atrium is a key element in the organizational planning of the building.

With an atrium, the air can be drawn from both sides of the building towards a central extract point, thereby doubling the width of the building that can be ventilated effectively by natural means. For natural ventilation to work effectively, the maximum distance from the building perimeter to the atrium must conform to the cross-ventilation limits. As with the chimney strategy, roof vents must be carefully positioned within the form of the roof so that positive wind pressures do not act on the outlets, causing reverse flow. In fact, it is normally possible to organize the outlets so that they are always in a negative pressure zone. This can be achieved by designing the roof profile so that for all wind angles, the opening is in a negative pressure zone or using multiple vents which are automatically controlled to close on the windward side and open on the leeward side. As for chimneys, natural ventilation can be supplemented on hot still days by using extract fans in the atrium roof.

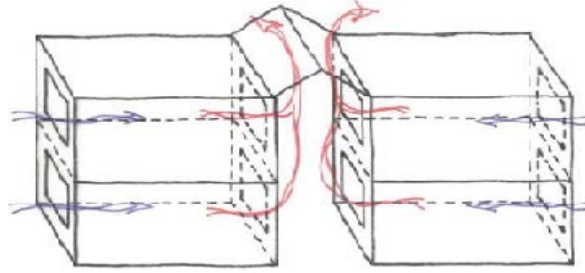

A typical natural ventilation strategy with an internal atrium

Advantages:

An atrium can be used as a ventilation air supply unit, an extract unit or as both at the same time. Atria have several advantages and drawbacks in common with double facades. Important advantages are:

- They allow windows to be opened in rooms facing the atrium irrespective of wind or low outdoor temperatures, and noise from the outside will be damped.
- When used as ventilation air supply path, they offer preheating of the air on sunny days
- When used as supply air path, transmission heat losses from the surrounding spaces will be captured by the inlet airflow; thus a heat recovery effect is provided.
- On cold days, surface temperatures of windows towards an atrium are higher than on windows facing outdoor climate. Thus, the risk for cold downdraft and thermal discomfort due to asymmetric radiation in the rooms inside is lower.
- Atria collect solar heat and provide protection against wind. Thus, transmission losses from rooms towards an atrium are lower than for rooms facing outdoor climate.

Drawbacks:

- High temperatures can be a problem on hot days.
- Noise can be transferred between adjacent rooms by reflection in the glazed cavity surface.

VENTILATION CHAMBERS

Ventilation chambers are in this context defined as spaces within the building with the primary purpose to distribute, collect or transport ventilation air.

A typical application is a chamber serving as a supply air duct, receiving outdoor air and distributing it to the occupied parts of the building.

Another application is a chamber receiving polluted air from the occupied parts of the building. The purpose might then be to collect the extract air in order to recover heat and take better advantage of the stack or wind potential by leading it into suitable elements like a chimney or a wind tower.

Separate ducts or chambers within the building are central inlet paths. An important drawback is that they occupy space.

VENTILATION OPENINGS IN THE FACADE

Ventilation openings in the façade are designed for the sole purpose of providing ventilation inlets and/or outlets. They are therefore separated from windows which also serve other purposes, i.e. providing daylight and view to the outside (and to the inside).

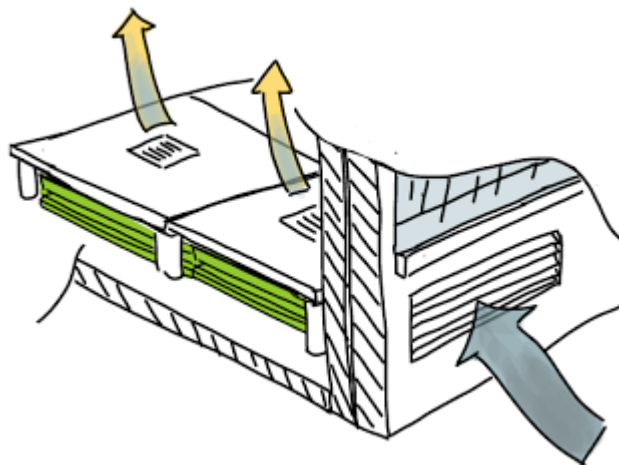

Ventilation inlets in the façade are often used in combination with local supply and extract of ventilation air. They need to have a certain size to support a sufficient air change rate with a low pressure-drop. Therefore, they influence the architectural expression of the façade. Local supply/extract of ventilation air does not need a special distribution system within the interior.

Wing Walls

To increase the cooling effectiveness of natural ventilation techniques, especially a single sided opening and on sites with low outdoor air velocity and variable wind directions, it is possible to incorporate wing walls into the building design.

Wing walls project outward next to a window; even a slight breeze against the wall creates a high pressure zone on one side and low on the other. The pressure differential draws outdoor air in through one open window and out the adjacent one. This technique is effective for wind direction angles from 20° to 160°. For single-sided ventilation without a wing wall, high air velocity is found near the openings, and the air velocity decreases substantially with the depth of the room.

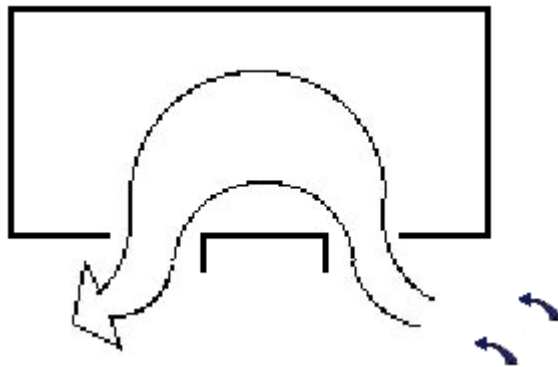

Deflection by Hedges

There are many possibilities for directing and deflecting winds. Deflection of up to 90° is possible.



DESIGN CODES & STANDARDS

According to 2009 ASHRAE Fundamentals, “Natural ventilation is the flow of outdoor air caused by wind and thermal pressure through intentional openings in the building’s shell.”

ASHRAE Standard 62.1-2010 section 6.4 sets the opening sizes and configurations required for an area to be defined as naturally ventilated, and advises that mechanical ventilation systems are required to be present in conjunction with natural ventilation systems except when an engineered natural ventilation system is provided or an unconditioned zone has permanently open openings during all times of expected occupancy.

ASHRAE Standard 55-2010 sets occupant-access and temperature-based limitations on the use of an extended range of acceptable temperatures to define comfort under natural conditioning (i.e., natural ventilation that is controlled by occupants to adjust thermal conditions in a space).

Additional standards effecting ventilation practice have been developed by the:

- American Conference of Governmental Industrial Hygienists (ACGIH): It provides threshold limit values for chemical substances and physical agents and biological exposure indices.
- Occupational Safety and Health Administration (OSHA) (1989), Air Contaminants (Title 29, Code of Federal Regulations, Part 1910.1000): It examines the permissible exposure limits (PEL) for air contaminants.

Federal energy standards: The U.S. Department of Energy (DOE) has updated 10 CFR 435 to reflect the codified version of the American Society of Heating, Refrigerating and Air-Conditioning Engineers, Inc. / Illuminating Engineering Society of North America (ASHRAE/IESNA) Standard 90.1 to be closer to the existing voluntary sector code. This new federal standard, 10 CFR 434 Energy Code for New Federal Commercial and Multi-Family High Rise Residential Buildings, is mandatory for all new federal buildings. For existing buildings, refer to ASHRAE 100 Energy Conservation in Existing Buildings. For residential buildings, the applicable standard is ASHRAE 90.2 Energy Efficient Design of Low-Rise Residential Buildings. Methodology and Procedures for Life-Cycle Cost Analysis are described in 10 CFR 436.

Observe all codes and standards regarding transport of smoke and fire when deciding on the applicability of natural ventilation and in the design of the system.

DESIGN TOOLS & SOFTWARE

Many computer programs are available for predicting ventilation patterns. Some that use the “zonal” method may be used to predict ventilation rate (mechanical and natural), magnitude and direction of air flow through openings, air infiltration rates as a function of climate and building air leakage, pattern of air flow between zones, internal room pressures, pollutant concentration, and back drafting and cross contamination risks. These models take the form of a flow network in which zones or rooms of differing pressures are interconnected by a set of flow paths. This network is approximated by a series of equations representing the flow characteristics of each opening and the forces driving the air flow process.

In order to predict the details of natural airflow, numerical computational fluid dynamics (CFD) program is a more accurate and complex tool for modeling airflow through a space based on pressure and temperature differentials. These programs can simulate and predict room airflow, airflow in large enclosures (atria, shopping malls, airports, exhibitions centers, etc.), air change efficiency, pollutant removal effectiveness, temperature distribution, air velocity distribution, turbulence distribution, pressure distribution, and airflow around buildings.

These computer simulations are detailed and labor intensive but are justified where accurate understanding of airflow is important. Software packages for natural ventilation analysis include:

1. AIRPAK – It provides calculation of airflow modeling, contaminant transport, room air distribution, temperature and humidity distribution, and thermal comfort by computational fluid dynamics.
2. FLOVENT – It calculates airflow, heat transfer and contamination distribution for built environments using computational fluid dynamics. This software is particularly geared towards ventilation calculations including natural and forced convection currents. It also accurately calculates air density as a function of temperature and predicts the resulting buoyancy forces that can give rise to important thermal stratification effects.
3. FLUENT – It is a computational fluid dynamics program useful in modeling natural ventilation in buildings. It models airflow under specified conditions, so additional analysis is required to estimate annual energy savings. FLUENT is

- a sophisticated analysis technique that can, among other things, model and/or predict fluid flow behavior, transfer of heat and behavior of mass.
4. STAR-CD – It uses computational fluid dynamics to help civil engineers, architects and project managers who need better and more detailed understanding of issues involved in heating and ventilation, smoke and pollutant dispersal analysis, fire hazard analysis and clean room design.
 5. DOE-2 – It is a comprehensive hour-by-hour simulation; day lighting and glare calculations integrate with hourly energy simulation.
 6. ENERGY PLUS – It is a building energy simulation program designed for modeling buildings with associated heating, cooling, lighting, ventilating and other energy flows.

In general, while building models incorporate very limited features for deliberate natural ventilation, all these software's include the calculation of natural air infiltration as a function of temperature difference, wind speed, and effective leakage area. Alternatively, they may include schedules and user-defined functions for infiltration rates.

Summary

Natural ventilation is a whole-building design concept. The design utilizes the stack effect and wind pressures to supply outdoor air to building interiors for cooling purposes. When ventilating a building using natural ventilation, two distinct design strategies must be considered: one for the winter and one for the summer. During winter only small air flows are needed, but there is the risk of cold air drafts. During the summer, the main challenge is providing enough air flow to give effective cooling. Features of naturally ventilated buildings include exhaust vents located high in the building with intakes located low in the building, as well as open building plans to facilitate air movement.

Natural ventilation reduces energy consumption for fans and mechanical cooling, and in most cases gives occupants control over their space. The real advantages of a natural ventilation system are two-fold:

- No expenses for ventilation equipment, electrical operation and maintenance; and
- No problems created by "brown-outs" or "black-outs" caused by storms or insufficient generation capabilities.

As the cost of energy and the likelihood of power failures increase, the natural ventilation systems become more desirable.

Natural ventilation in most climates will not move interior conditions into the comfort zone 100% of the time. Make sure the building occupants understand that 3% to 5% of the time thermal comfort may not be achieved. This makes natural ventilation most appropriate for buildings where space conditioning is not expected. Some designs use mechanical systems to provide outdoor air for occupants but use natural ventilation to provide cooling.

As a designer it is important to understand the challenge of simultaneously designing for natural ventilation and mechanical cooling. It can be difficult to design structures that are intended to rely on both natural ventilation and artificial cooling.
